

Robotic Solutions to Oil Field Problems

Daniel Allford
President
ARC Specialties
Houston, Texas

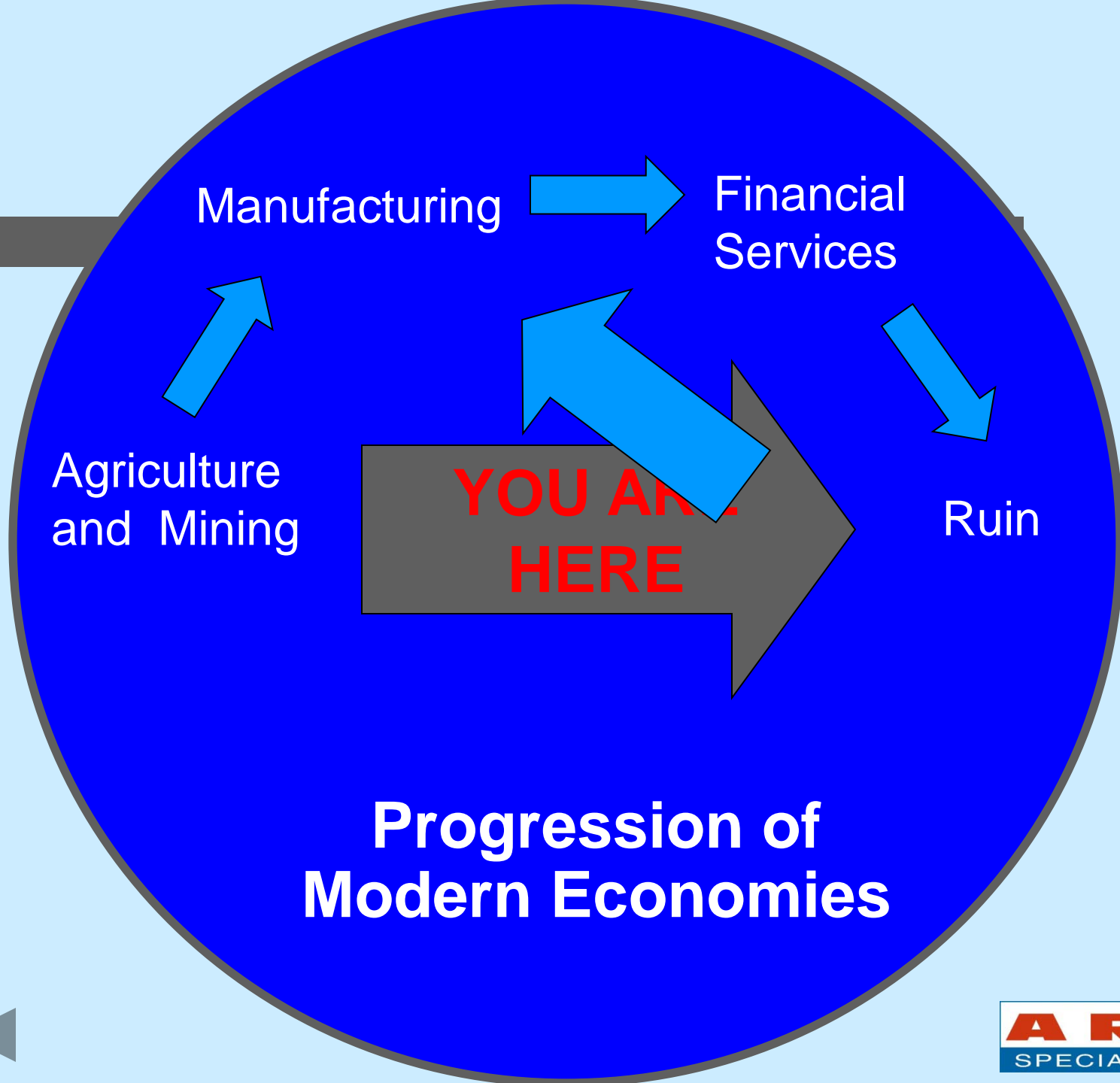

Manufacturing

Financial Services

Agriculture and Mining

Ruin

**YOU ARE
HERE**

**Progression of
Modern Economies**

Our Economy Needs To Return To Manufacturing Base

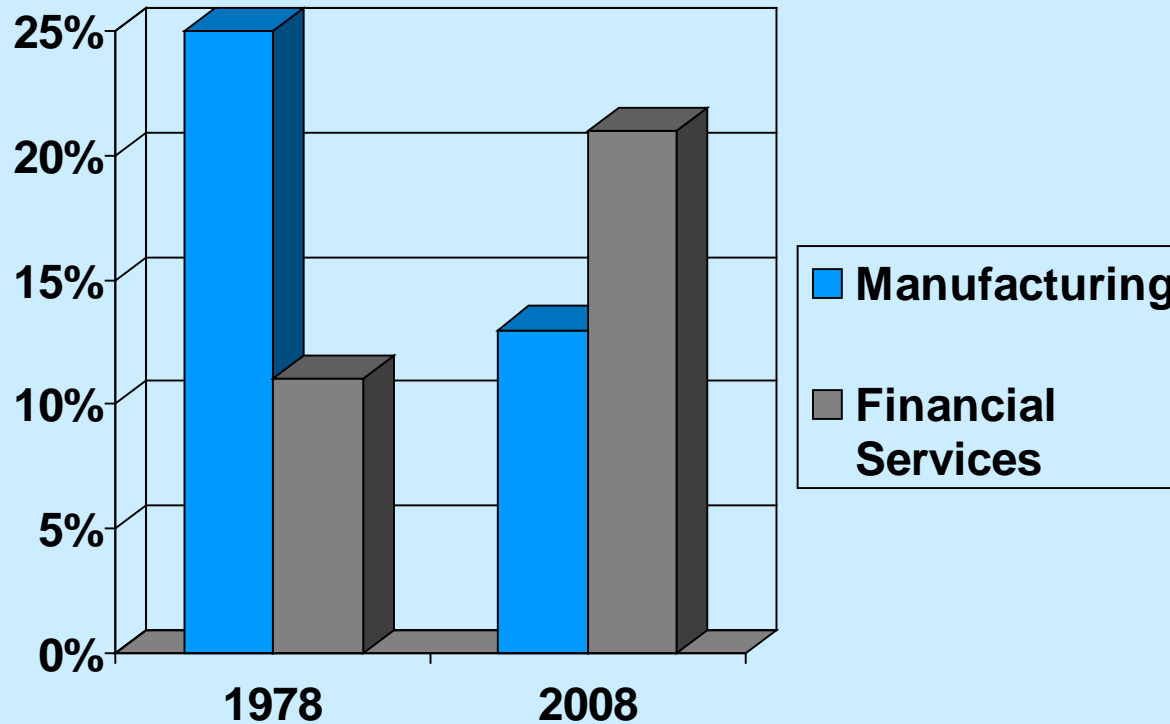

According to some economists, manufacturing is a wealth-producing sector of an economy, whereas a service sector tends to be wealth-consuming.



Good News: History is Encouraging!

- 17th century Spain, RECOVERED!
- 18th century Holland, RECOVERED!
- 19th and early 20th century Britain RECOVERED!
- 21st century USAto be determined



Robots: Another Tool for Manufacturing. Not Just For MIG



2/13/2009

Robots: Another Tool for Manufacturing. APPLICATIONS



Joining



Metal to Metal Wear



Cutting



Corrosion



Ground Engaging Wear

Robots: Another Tool for Manufacturing. PROCESSES

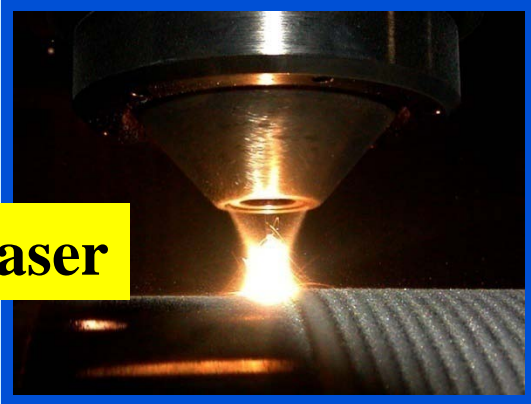

Laser



Gas Tungsten Arc TIG



OxyFuel

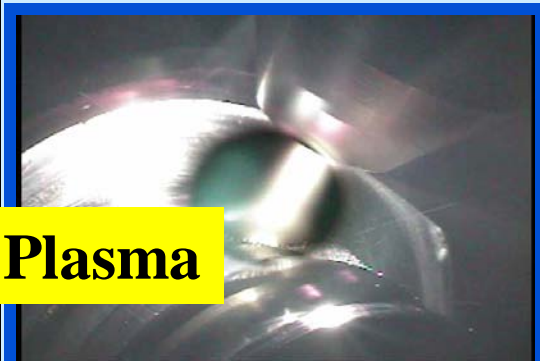

Plasma



Submerged Arc



Joining Applications: Shale Shaker Screens

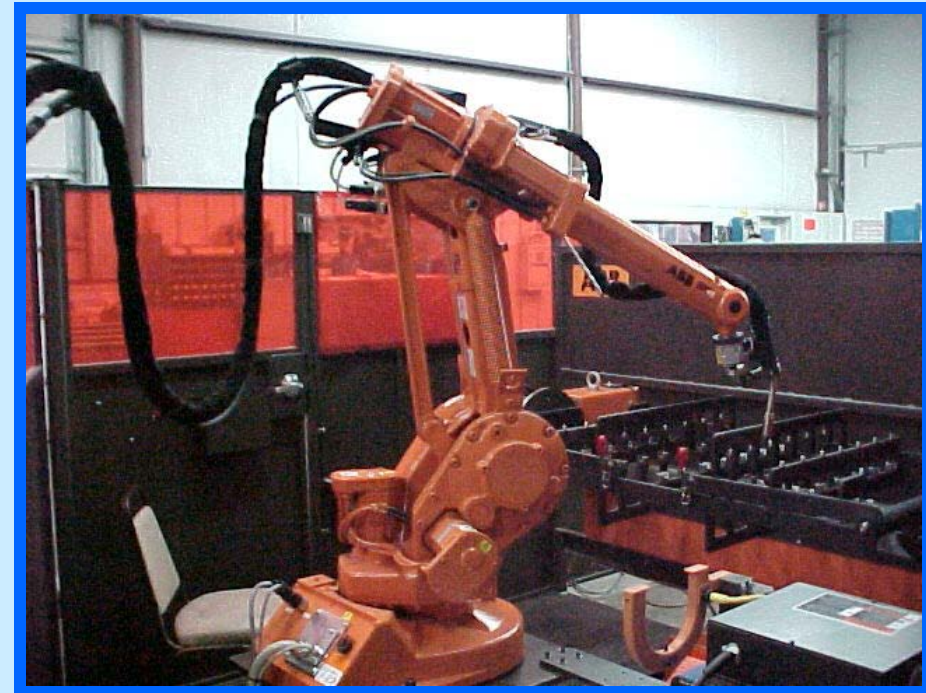

Joining Application Adaptive Control Options

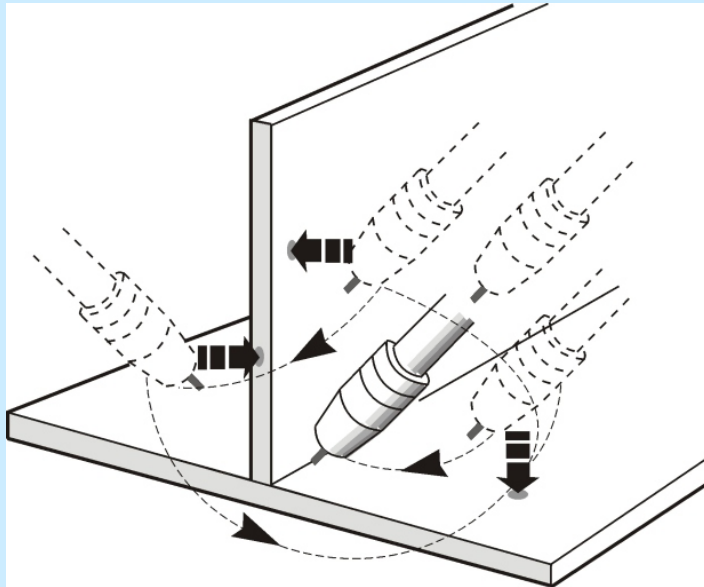

Touch Sensing



Machine Vision



Metal to Metal Wear

Old Technology: Oxygen Fuel Welding

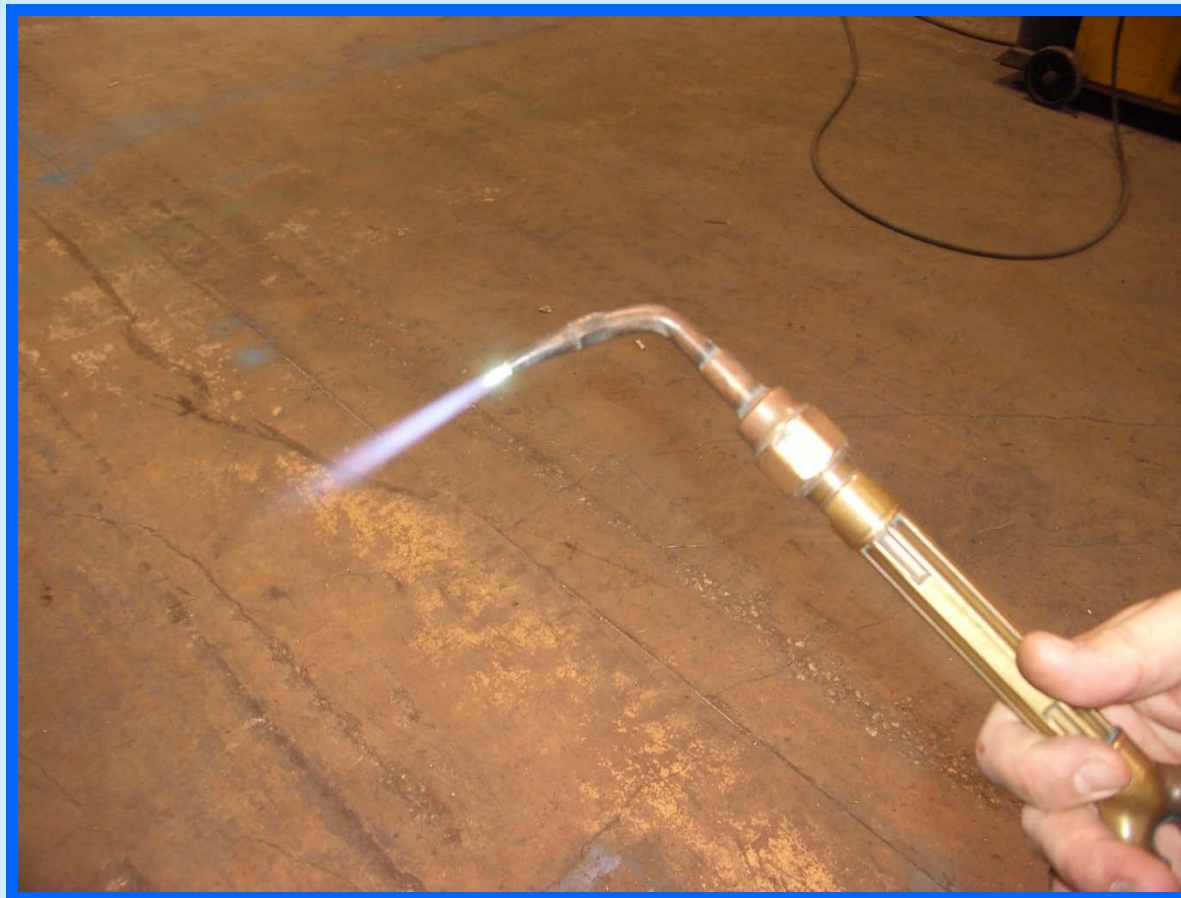

Metal to Metal Wear

New Technology: Plasma Transferred Arc Welding



Metal to Metal Wear

New Technology: Plasma Transferred Arc Welding

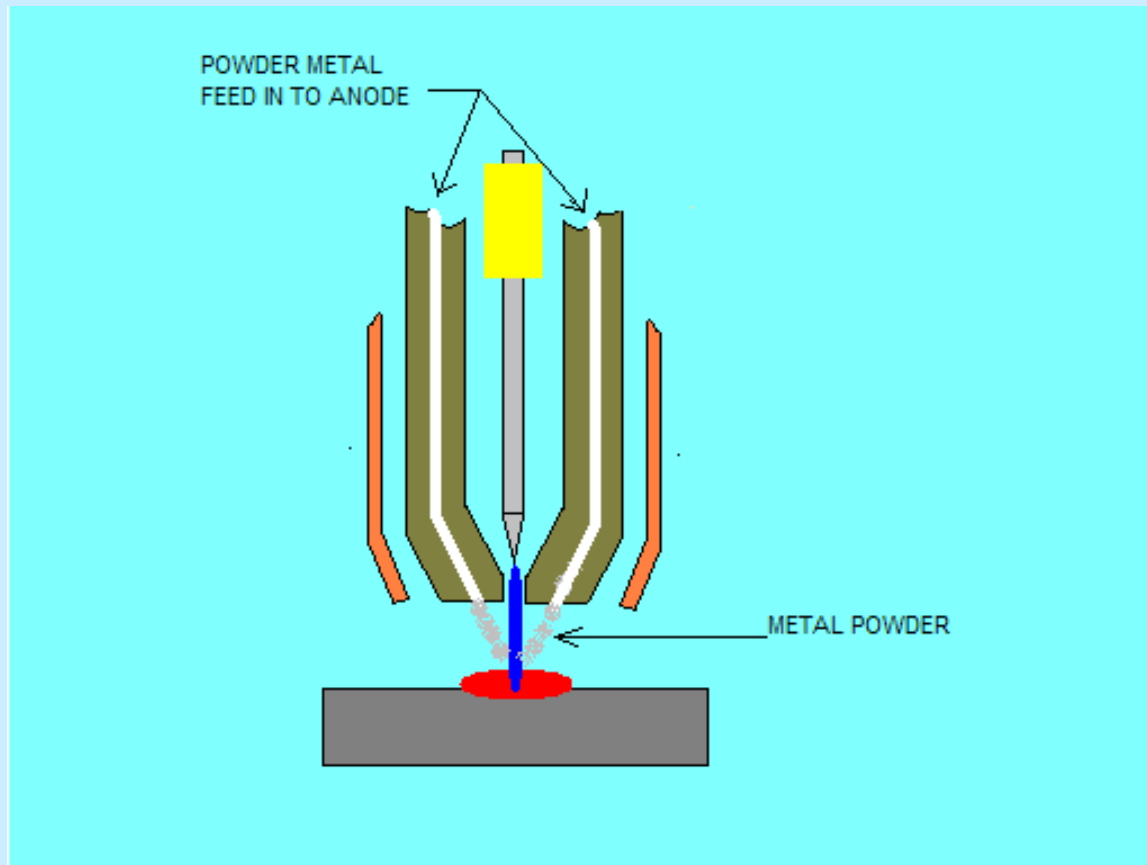

Metal to Metal Wear

New Technology Powder Filler Materials

Cobalt Based Bearing Alloys



Metal to Metal Wear

New Technology: Plasma Transferred Arc Welding



Metal to Metal Wear

Plasma Hard Faced Journal Bearing



Metal To Metal Plasma Welding with Offline Programming

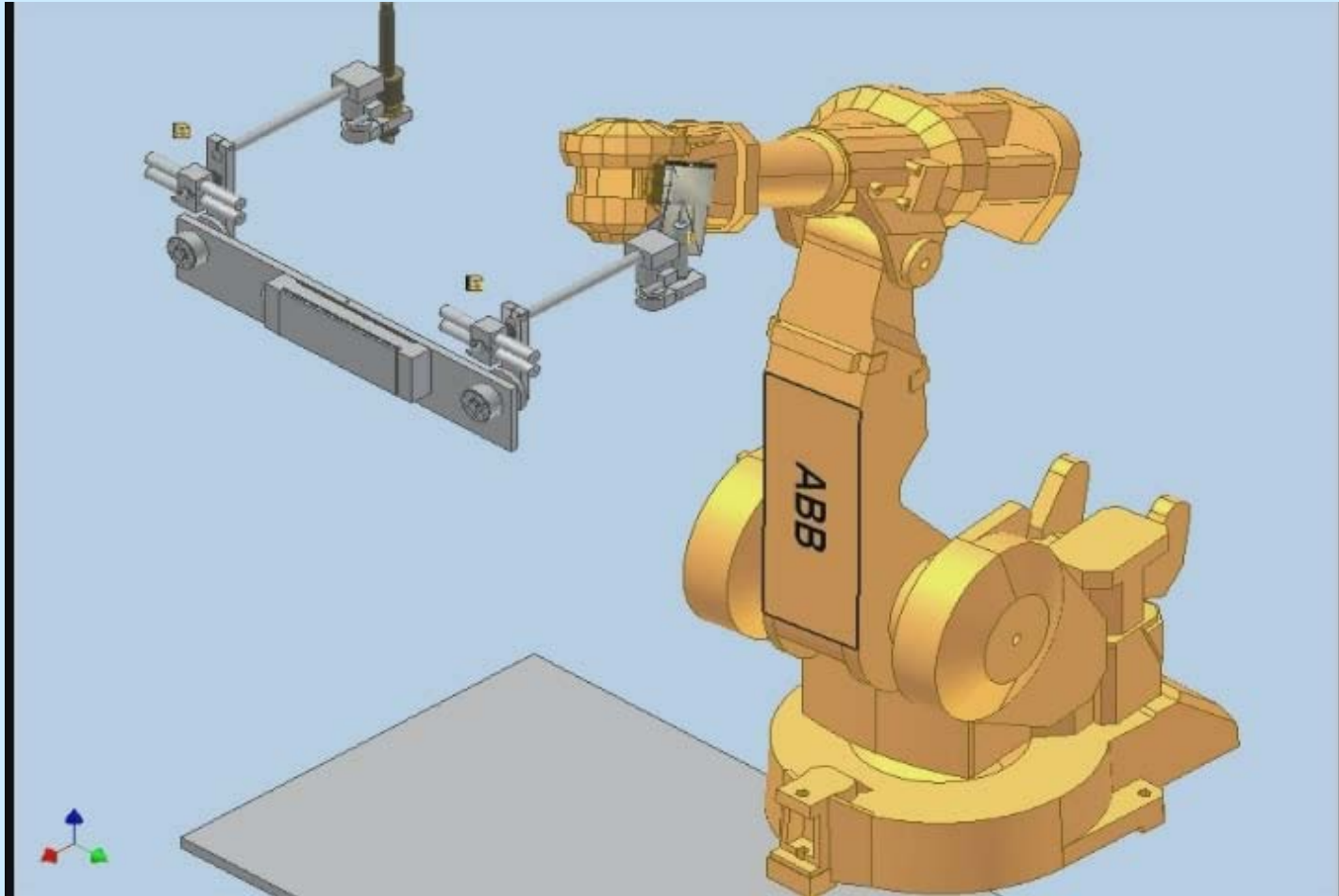

Metal To Metal Plasma Welding with Offline Programming



Ground Engaging

Old Technology: Atomic Hydrogen Welding



Ground Engaging Old Technology: Tungsten Carbide Filled Tubular Filler Materials

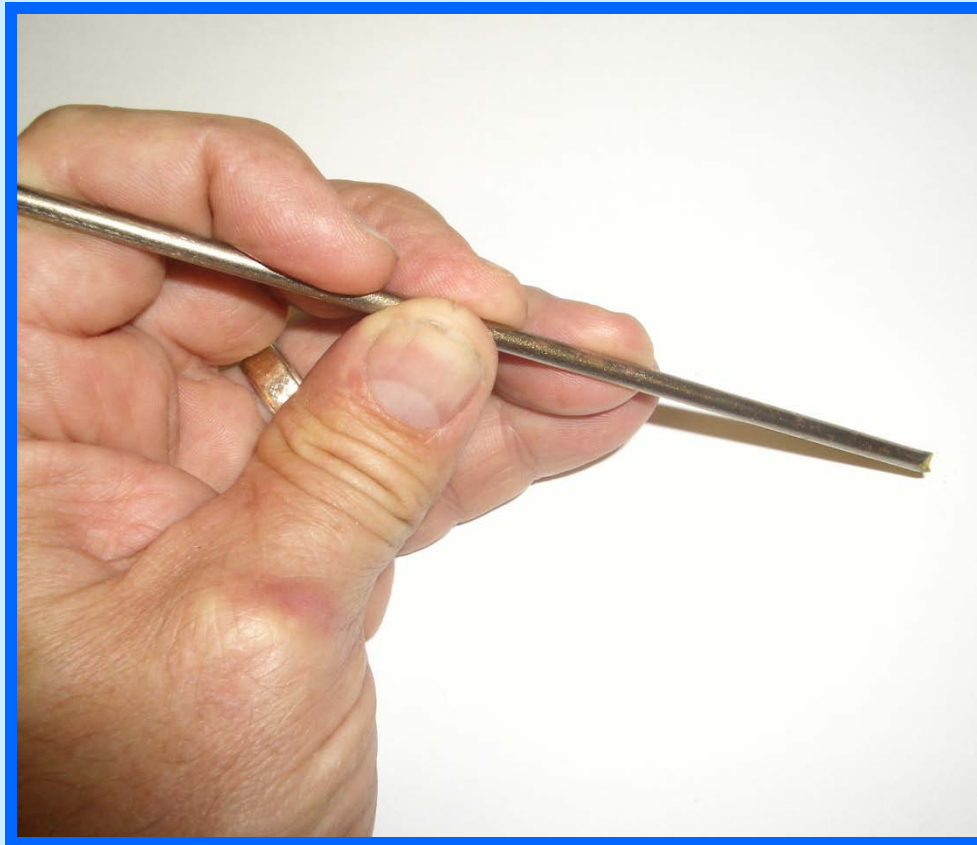

Ground Engaging Plasma Welding with Robot Holding the Part



Ground Engaging Small Parts



Ground Engaging Large Parts



Cutting Oxy Fuel and Plasma



Ground Engaging Wear Applications

Composite Hard Facing: Steel Wire + Tungsten Carbide

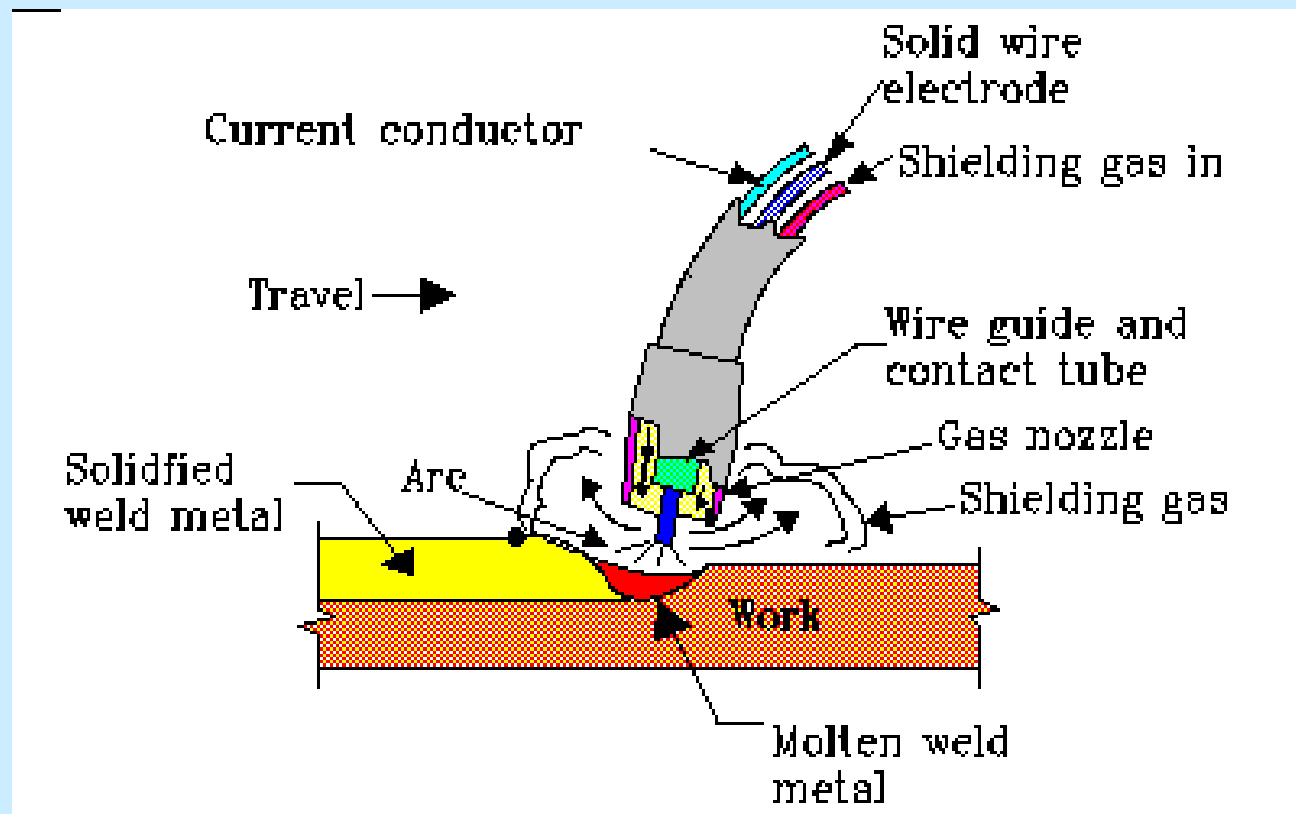

Ground Engaging Wear Applications Composite Hard Facing Steel Wire + Tungsten Carbide



Ground Engaging Wear Applications Composite Hard Facing Steel Wire + Tungsten Carbide

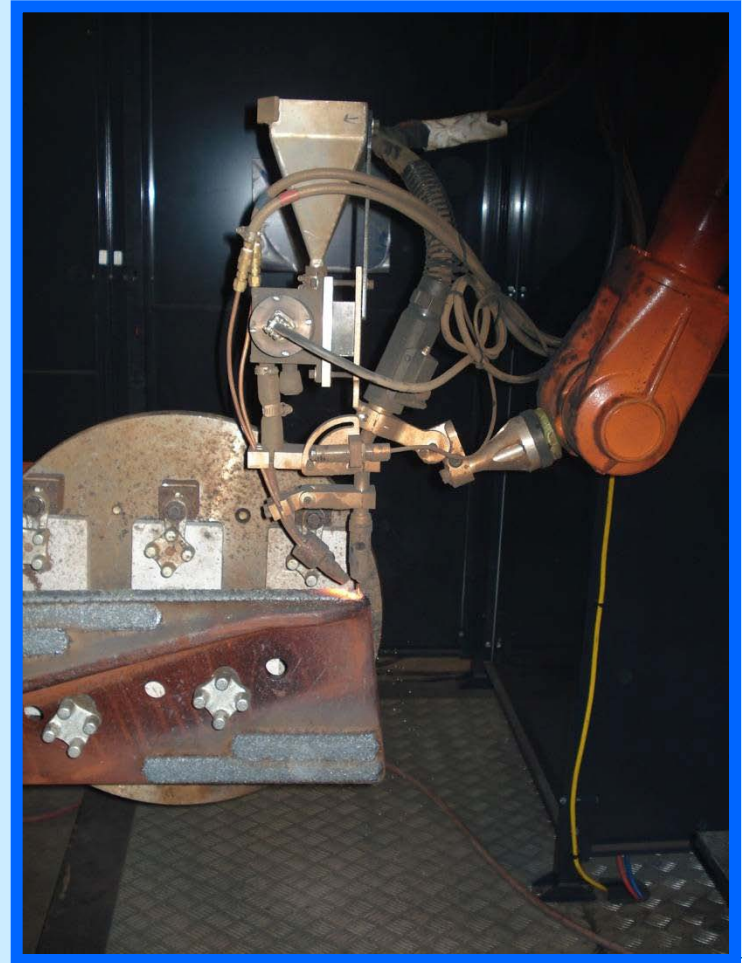

Ground Engaging Wear Applications Composite Hard Facing Steel Wire + Tungsten Carbide



Fabrication: Combining Plasma Gouging and Welding

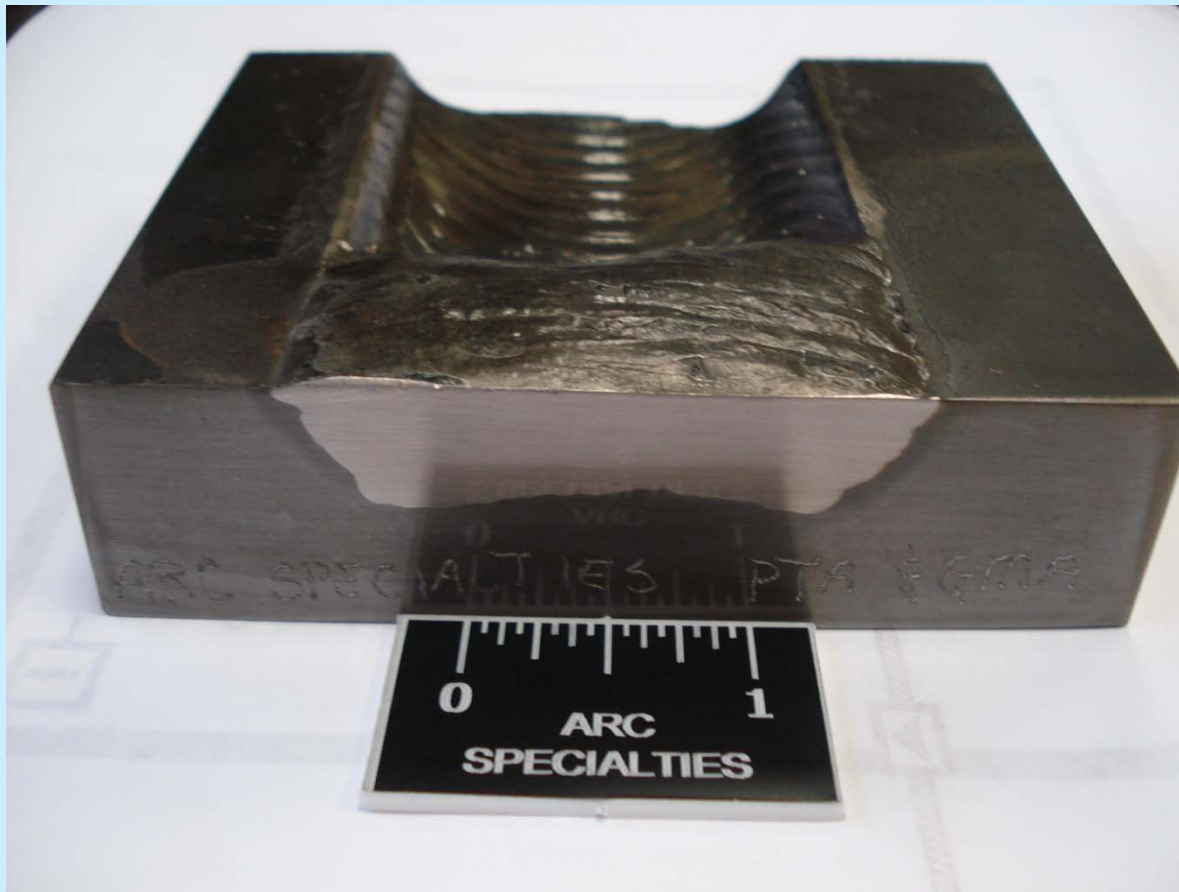

VIDEO



3D Metal Spray



Robotic Thermal Spray

Your Single Source For Engineering,
Process, Machine & Controls®

ARC
SPECIALTIES

Fabrication Application

Cut To Fit: Solve Fit Up Problems Before They Happen



2/13/2009

Corrosion

GMA applied Nickel Base Coating



Corrosion SAW Applied Nickel Base Coating

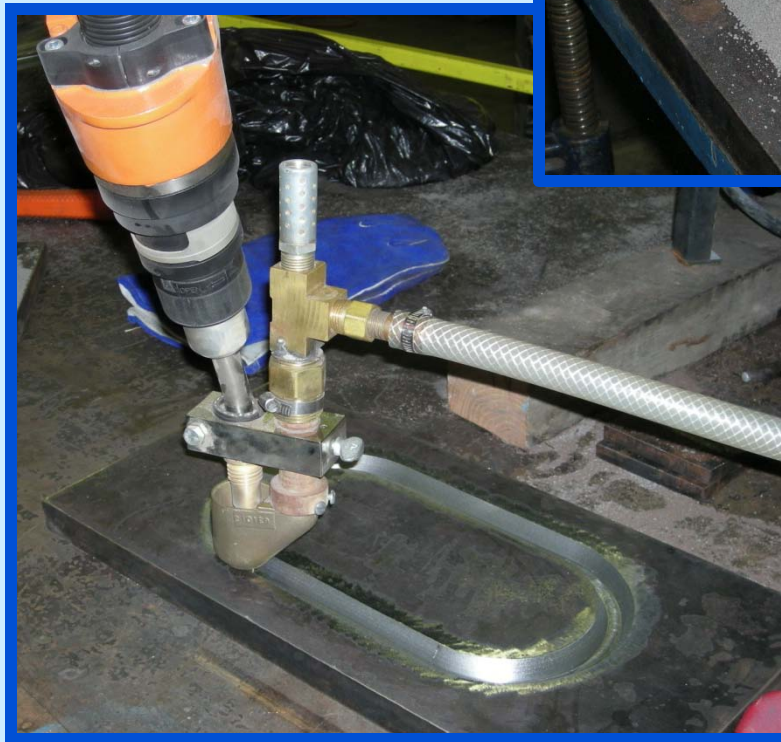

Plug Welding Using Laser Height and 2D Vision

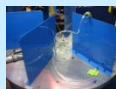
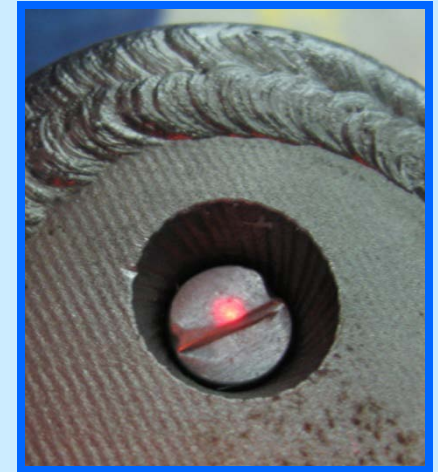

VIDEO

2/13/2009

Finishing Application

Polishing Using Force Feedback

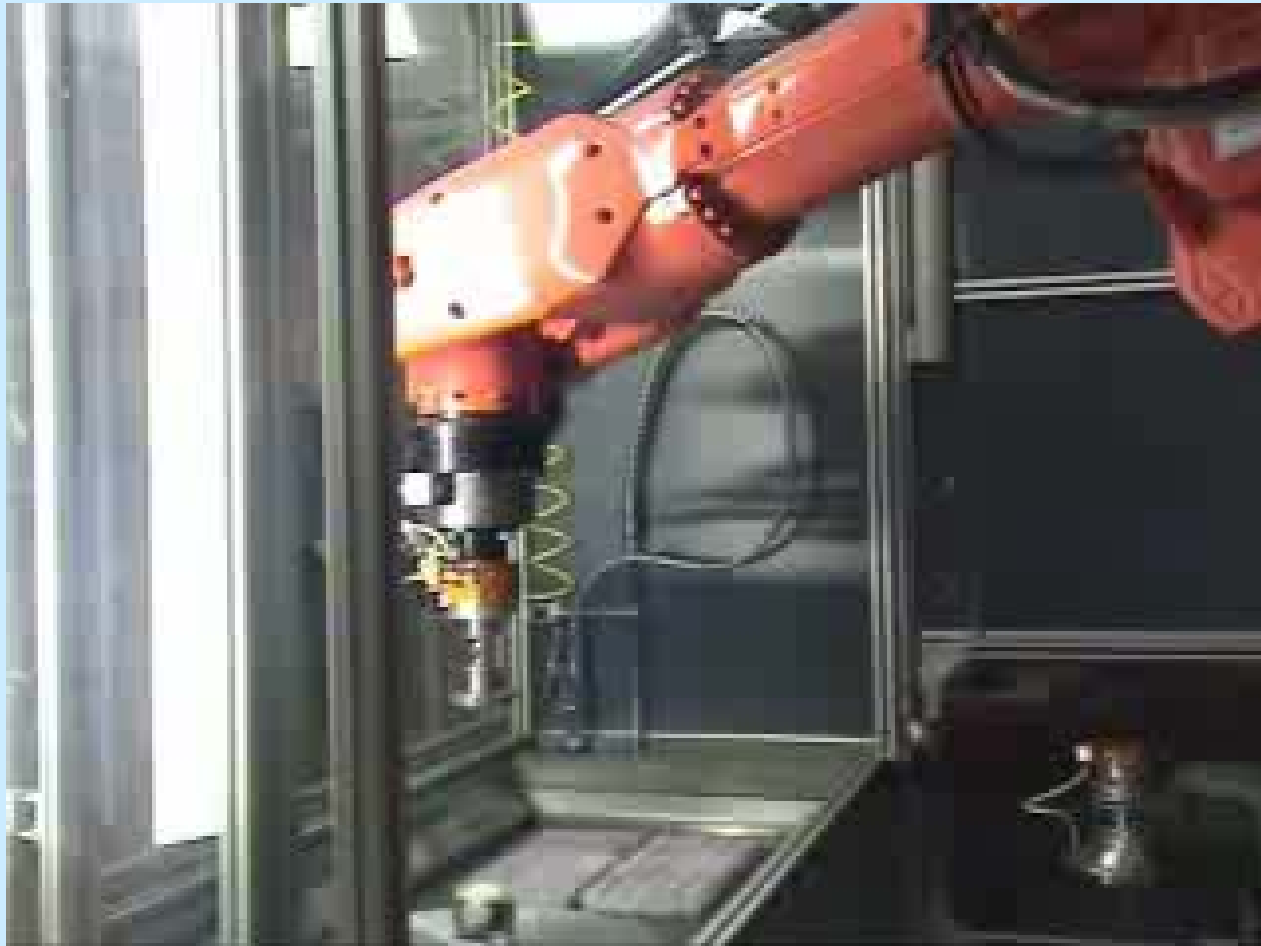

2/13/2009

Thanks For Attending



Watch For the 260 MPH ABB Robot At NHRA Drag Racing Events

